

# STORM WATER POLLUTION PREVENTION PLAN

FOR

GENERAL SITE – FRANCIS QUADRANGLE – IRRIGATION,  
DRAINAGE, AND TURF REPLACEMENT  
PROJECT NO. CP241991

Date:

April 04, 2024



PREPARED BY:

**CROCKETT**  
ENGINEERING CONSULTANTS

1000 W. Nifong Blvd., Bldg. 1, • Columbia, Missouri 65203

# GENERAL PROJECT INFORMATION

## PROJECT

GENERAL SITE – FRANCIS QUADRANGLE – IRRIGATION, DRAINAGE, AND TURF REPLACEMENT

## PROJECT LOCATION

General Location: Francis Quadrangle

## GENERAL DESCRIPTION OF PROJECT

Grading of existing greenspace for installation of new turf and new storm sewer.

**MU DESIGNATED REPRESENTATIVE FOR ENVIROMENTAL ISSUES:** Michael Stornello

## PROJECT PROPERTY OWNER

Name: Curators of the University  
Address: 225 University Hall  
City: Columbia State: MO Zip: 65211  
Phone: (573) 884-7146  
Contact: Jennifer Sullivan

## GENERAL CONTRACTOR

Name: \_\_\_\_\_  
Address: \_\_\_\_\_  
City: \_\_\_\_\_ State: \_\_\_\_ Zip: \_\_\_\_\_  
Phone: \_\_\_\_\_ Fax: \_\_\_\_\_  
Contact: \_\_\_\_\_

## CONSULTANT

Crockett Engineering Consultants  
1000 W. Nifong Blvd., Bldg. 1  
Columbia, MO 65203  
Phone: 573.447.0292  
Contact: Nathan Eckhoff

## EROSION CONTROL INSPECTOR

Name: \_\_\_\_\_  
Address: \_\_\_\_\_  
City: \_\_\_\_\_ State: \_\_\_\_ Zip: \_\_\_\_\_  
Phone: \_\_\_\_\_ Fax: \_\_\_\_\_  
Contact: \_\_\_\_\_

**MU DESIGNATED REPRESENTATIVE FOR ENVIRONMENTAL ISSUES:** Michael Stornello

**NOTE:** The Owner must designate an approved **EROSION CONTROL INSPECTOR**, who will be responsible for the inspection logs, updating the **SWPPP**, and reporting to the site manager any noncompliance findings.

The **GENERAL CONTRACTOR** shall notify the **EROSION CONTROL INSPECTOR** when a precipitation event occurs.

The person selected to conduct inspections should be knowledgeable in the principles and practices of erosion and sediment controls, possess the technical skills to assess conditions at the construction site that could impact stormwater quality, and assess the effectiveness of any erosion and sediment control measures selected.

## SWPPP OBJECTIVES

- Stabilize the site as soon as possible
- Protect slopes and channels
- Reduce impervious surfaces and promote infiltration
- Control the perimeter of the site
- Protect adjacent receiving waters
- Follow pollution prevention measures
- Minimize the area disturbed and the duration of bare soil exposure

## SWPPP REQUIREMENTS

- Nature of construction activity
- Site map
- Site description
- Selection of permanent and temporary BMPs
- Preservation of trees and vegetation
- Surface water buffers
- Measuring buffer width
- Description of BMPs
- Specific instance of BMPs
- Disturbed areas
- Installation
- Sedimentation basins
- Pollution prevention measures
- Roadways
- Dewatering

## REMINDER

- The SWPPP must remain on site until the site has been closed out.
- A copy of the permit and/or NOI needs to be attached to the SWPPP.
- Modifications and updates to BMPs or drainage areas on the project site should be recorded in or attached to the SWPPP.
- Any additional Federal, State, or Local permits need to be attached to the SWPPP.
- The SWPPP, as well as all supporting documentation (permits, inspection reports, addendums, to the SWPPP, location map, site plan, NOI/NOT etc.), must be retained for three (3) years.
- SWPPP's are amendable and can be changed during the course of the construction process. The goal of the SWPPP is to keep sediment on the project sites and assure water quality standards. If BMPs or procedures are not attaining this goal, then the SWPPP may be changed or updated in order to better address specific conditions.

## SITE MAP CONSIDERATIONS

Site maps should show the construction activities and stormwater management practices for each major phase of construction (e.g., initial grading, infrastructure, construction, and stabilization). Site maps should identify the following features:

- Areas and features to be protected
- Disturbed areas (locations and timing of activities)
- Clearing limits
- Identify locations of structural and non-structural BMPs
- Identify locations of Post-construction BMPs
- Areas of stabilization
- Indicate locations of material, waste, borrow, or equipment storage

Site maps should be kept up to date showing changes that have been made to BMPs and for stabilization methods as the site progresses. The Missouri State Operating Permit requires that the SWPPP and site map be kept up to date, so mark up the site map with the locations and dates of any changes being made. Also include the current locations of the following:

- Portable toilets
- Material storage, vehicle and equipment fueling and maintenance areas
- Concrete, paint and stucco washouts
- Dumpster containers
- Spill kits
- Stockpiles
- Any other non-structural non-stormwater BMPs, temporarily removed structural BMPs or changes to the structural BMPs

# PROJECT PLANNING & DESIGN

**SOIL DISTURBING ACTIVITIES** for this project will include the following (check all that apply):

- Clearing and grubbing of existing vegetation
- Construction of sediment basins and stormwater detention
- Stripping of topsoil within the limits of construction
- Stockpiling and re-spreading topsoil
- Utility trench excavation and backfill
- Preparing subgrade for streets and sidewalks
- Backfilling curbs and sidewalks
- Disposal areas for excess excavated material
- Borrow areas for fill material
- Construction of compacted fill areas for residential/commercial building construction
- Other (specify): \_\_\_\_\_

**NOTE:** The Site Plan must be submitted with the SWPPP.

Limits of Land Disturbance must be clearly shown on the Erosion and Sediment Control Plan.

## WHAT IS THE FUNCTION OF THE CONSTRUCTION ACTIVITY?

- Clearing/Grading
- Residential Subdivision
- Municipality

## SITE RUNOFF CHARACTERISTICS

Total Site Area: 2.61 acres

Estimated Area to be disturbed by all activities: 2.61 acres

Runoff Coefficient prior project: 0.30

Runoff Coefficient after project: 0.30

Name Watershed and Receiving Waterbody: Tributary to Flat Branch Creek

Pre-Project Peak 10 year outflow: 5.64 cfs

Post-Project Peak 10 year outflow: 5.64 cfs

## PROJECT PLANNING & DESIGN

**Endangered or threatened species/critical habitats on or near the project?**  Yes  No

Description of species and/or critical habitat: \_\_\_\_\_

Steps taken to address the impact of construction: \_\_\_\_\_

**Historic Sites on or near the construction site:**  Yes  No

Steps taken to address the impact of construction: \_\_\_\_\_

**Will there be work done in a 404/401 stream or creek?**  Yes  No

Steps taken to address the impact of construction: **There are no streams in this project that would be classified as a 404 or 401 stream.**

**NOTE:** A Limited Stream Assessment must be submitted

**Are there any impaired waters on the site?**  Yes  No

If yes, has a Total Maximum Daily Load (TMDL) been developed?  Yes  No

### **GENERAL DESCRIPTION OF STORMWATER MANAGEMENT PLAN**

To ensure that this project does not promote or aggravate an existing off-site erosion, siltation, or drainage problem, erosion best management practices (BMP's) are to be implemented on this site. The BMP that has been chosen for this site is inlet protection. Due to the minimal land disturbance within the project scope, it is expected that small amounts of silt laden runoff will be generated. To ensure proper containment of said silt laden runoff, silt fence will be utilized to filter the runoff prior entering the storm network. The above referenced erosion control devices are to be placed in areas of highly concentrated flows or sources of point flow and sheet flow.

All drainage structures flow to central north portion of Francis Quadrangle where it connects in a junction box and leaves the site via pipe network. From here, the storm system carries the discharge to Flat Branch Creek. Refer to site maps. The storm structure designated as the outfall is also shown on sheet CE 2.1.

Sheet CE 2.1 contains the location of structural BMPs and designated points where vehicles will exit the site. Sheet L-100 contains the existing and proposed grades, this sheet also contains pipe networks, swales, and other stormwater conveyance items. Sheet L-200 specifies where sod replacement is expected to occur, this acts as soil stabilization.

### **GENERAL DESCRIPTION OF STORMWATER FACTOR AFFECTING RUNOFF**

During construction, the site will manage runoff with traditional BMP practices including silt fence. The post-project site will manage the runoff on our site from entering the downstream waters. With the use of these factors the discharge runoff rate on this site will be less than the existing conditions.

# CONSTRUCTION PHASE

## IMPORTANT RECORDED DATES (to be filled in during construction activities)

---

Major grading activities begin and end (dates): \_\_\_\_\_

Construction temporarily or permanently ceased (dates): \_\_\_\_\_

Stabilization measures initiated (dates): \_\_\_\_\_

**BLASTING** (list all contractors who will perform blasting work or handle explosives. Attach insurance certificates for all contractors on this list):

---

---

## GENERAL SEQUENCE OF CONSTRUCTION:

---

Describe the general sequence/phasing of construction. (Address any critical construction sequences, time restrictions, etc. of which the contractor must be aware in planning his activities.)

This project will be completed in two general phases. The first task of construction will be the installation and inspection of all erosion control facilities. These facilities must be placed as per the approved land disturbance plan and SWPPP. Once the facilities have been properly installed, grading of the site can begin. Any disturbed slopes shall be fine, seeded, and mulched as soon as practical to provide a stabilized surface.

The second phase will include a majority of the site grading. All disturbed areas that are not covered by new turf shall be seeded and mulched. The erosion control facilities shall remain in place throughout this process. The disturbed areas are to be periodically inspected to check for wash-outs, gulleys, scouring, etc. Should any of these situations exist, the affected area shall be regraded, reseeded, and remulched.

# CONSTRUCTION SITE BEST MANAGEMENT PRACTICES

(check all that apply):

- |  |  |
|--|--|
| <input checked="" type="checkbox"/> Scheduling               | <input type="checkbox"/> Slope Drains                          |
| <input type="checkbox"/> Preservation of Existing Vegetation | <input type="checkbox"/> Geotextiles, ECBs, or TRMs            |
| <input type="checkbox"/> Hydraulic/Wood Mulch                | <input type="checkbox"/> Earth Dikes/Swales & Lined Ditches    |
| <input type="checkbox"/> Hydroseeding                        | <input type="checkbox"/> Outlet Protection/Velocity Dissipater |
| <input type="checkbox"/> Soil Binders                        | <input type="checkbox"/> Stream bank Stabilization             |
| <input type="checkbox"/> Straw Mulch                         | <input type="checkbox"/> Other (specify) _____                 |

## TEMPORARY SEDIMENT CONTROL BMPs:

- |  |   |
|--|---|
| <input type="checkbox"/> Silt Fence                              | <input type="checkbox"/> Sediment/Desilting Basin                 |
| <input type="checkbox"/> Sediment Trap                           | <input type="checkbox"/> Check Dam                                |
| <input type="checkbox"/> Top Soil Diversion Berm                 | <input type="checkbox"/> Gravel Bag Berm                          |
| <input type="checkbox"/> Sandbag Barrier                         | <input checked="" type="checkbox"/> Street Sweeping and Vacuuming |
| <input checked="" type="checkbox"/> Storm Drain Inlet Protection | <input type="checkbox"/> Other (specify) _____                    |

## WIND EROSION & TRACKING CONTROL BMPs:

- |  |  |
|--|--|
| <input checked="" type="checkbox"/> Wind Erosion Control | <input checked="" type="checkbox"/> Stabilized Entrance/Exit |
| <input type="checkbox"/> Entrance/Outlet Tire Wash       | <input type="checkbox"/> Other (specify) _____               |

## GOOD HOUSEKEEPING BMPs:

- |   |   |
|---|---|
| <input type="checkbox"/> Water Conservation Practices | <input type="checkbox"/> Paving & Grinding Operations         |
| <input type="checkbox"/> Dewatering Operations        | <input type="checkbox"/> Illicit/Illegal Discharge            |
| <input type="checkbox"/> Temporary Stream Crossing    | <input type="checkbox"/> Detection Vehicle & Equipment        |
| <input type="checkbox"/> Clear Water Diversion        | <input type="checkbox"/> Cleaning Vehicle & Equipment Fueling |
| <input type="checkbox"/> Potable Water/Irrigation     | <input type="checkbox"/> Vehicle & Equipment Maintenance      |
| <input type="checkbox"/> Concrete Curing              | <input type="checkbox"/> Material/Equipment Use Over Water    |
| <input type="checkbox"/> Concrete Finishing           | <input type="checkbox"/> Other (specify) _____                |

## WASTE MANAGEMENT & MATERIALS POLLUTION CONTROL BMPs:

- |  |   |
|--|---|
| <input checked="" type="checkbox"/> Spill Prevention/Control | <input type="checkbox"/> Material Delivery/Storage/Use    |
| <input type="checkbox"/> Stockpile Management                | <input type="checkbox"/> Contaminated Waste Management    |
| <input type="checkbox"/> Concrete Waste Management           | <input type="checkbox"/> Hazardous Waste Management       |
| <input type="checkbox"/> Solid Waste Management              | <input type="checkbox"/> Sanitary/Septic Waste Management |
| <input type="checkbox"/> Liquid Waste Management             | <input type="checkbox"/> Other (specify) _____            |

## PERMANENT STABILIZATION BMPs:

- |   |  |
|---|--|
| <input type="checkbox"/> Velocity Dissipation | <input type="checkbox"/> Riprap Channel Lining |
| <input type="checkbox"/> Vegetative Buffers   | <input type="checkbox"/> Other (specify) _____ |
| <input type="checkbox"/> Sod Channel Lining   |  |

**NOTE:** All temporary BMPs must be in place before construction can begin.



# ENVIRONMENTALLY SENSITIVE AREAS

## **WETLAND PROTECTION:**

Protection methods for wetlands include:

- Appropriate setbacks that preserve the wetlands or wetland functions;
- Wetland mitigation, including wetland replacement;
- Wetland restoration or enhancement.

## **SINKHOLE OR CAVE-RELATED NON-BUILDABLE AREAS:**

- No grading or installation of parking areas, streets or other infrastructure within non-buildable areas.

## **DEVELOPMENT IN SINKHOLE DRAINAGE AREAS WITHOUT DISCHARGE TO SINKHOLE:**

- Development may occur in the immediate sinkhole drainage area if alternative surface drainage is provided away from the sinkhole,
- The water shall stay in the same surface drainage basin,
- The water shall not go into another sinkhole drainage area off the applicant's property.
- The immediate sinkhole drainage area which cannot be provided with an alternative drain- age system can be deleted from the development area.

**DEVELOPMENT IN SINKHOLE DRAINAGE AREAS WITH DISCHARGE TO SINKHOLE:** The sinkhole can be used for limited surface runoff drainage where alternative surface drainage methods cannot be provided if the following conditions are met:

- Runoff from the development is completely retained in a retention or detention basin.
- Enough runoff is diverted from the sinkhole drainage area so that the development of the remaining area does not increase the total quantity or deteriorate the water quality of runoff into the sinkhole.
- Where the sinkhole outlet is off site, either the runoff leaving the subject property must be shown to be no greater in flow or in quantity than that which existed before development, or easements must be obtained from owners of property where any increase in flow or quantity of water must go to reach the sinkhole outlet.

## **FILLING IN SINKHOLES AND SINKHOLE DRAINAGE AREAS:**

- No street shall be placed below an elevation of at least one (1) foot above the sinkhole ponding elevation and only when collapse of the sinkhole will not adversely affect the road.
- No increase in the ponding elevation will be allowed by grading or filling without a stormwater analysis approved by the Director.
- It shall be unlawful for any person to place, dump or deposit trash, debris, rubbish, brush, leaves, grass clippings, yard waste, hazardous waste or similar materials within a sinkhole.
- The alteration of land in a sinkhole by means of grading or the use of motorized equipment without a permit is not allowed.

## **BUFFER ZONE LIMITATIONS AND PROHIBITIONS:**

- Natural vegetative cover must be retained within a buffer zone.
- All construction activities including grading and filling are prohibited.
- Wastewater disposal or irrigation is prohibited.

## **BUFFER ZONE WIDTHS:**

- Wetlands (at least 50 ft.)
- Sinkholes (shall not be less than 150 ft., or greater than 300 ft. from the sinkhole eye)
- Other environmentally sensitive areas (the buffer zone shall be at least 50 feet)

# GENERAL PRACTICES

## GENERAL PRACTICES FOR CONSTRUCTION SITE RUNOFF CONTROL:

- Clearing and grading of natural resources shall not be permitted;
- Clearing techniques that retain natural vegetation and natural drainage patterns shall be used to the *maximum extent practicable*;
- Clearing shall not begin until all sediment control devices have been installed and have been stabilized;
- Cut and fill slopes *shall be no greater* than 33%
- Phasing shall be required on all sites disturbing greater than 40 acres;
- Soil must be stabilized within 14 days of clearing or inactivity of construction;
- Soil stockpiles shall be protected from allowing sediment to leave the site;
- Techniques shall be employed to prevent the blowing of dust or sediment from the site;
- Techniques that divert upland runoff past disturbed slopes shall be employed;
- Sediment controls shall be provided in the form of settling basins or sediment traps or tanks, and perimeter controls;
- Adjacent properties shall be protected by the use of a vegetated buffer strip, in combination with perimeter controls wherever possible;
- When a watercourse must be crossed regularly during construction, a temporary stream crossing shall be provided. *Note:* Work done within a waterway may need additional federal or state permits;
- A temporary access road or driveway shall be provided at all sites;
- Temporary boundary markers shall be clearly visible and installed at 100-foot intervals prior to clearing, joined with marking tape or fencing, to delineate stream buffer limits.

## GENERAL PRACTICES FOR MAINTENANCE AND INSPECTIONS:

- Inspection Frequency: All BMPs must be inspected in accordance to one of the schedules listed below. The inspection frequency shall be documented in the SWPPP, and any changes to the frequency of inspections, including switching between the options listed below, must be documented on the inspection form:
  - (a) At least once every seven (7) calendar days and within 48 hours after any storm event equal to or greater than a 2-year, 24-hour storm has ceased during a normal work day or within 72 hours if the rain event ceases during a non-work day such as a weekend or holiday A 2-year, 24-hour storm event shall be determined for the project location using the National Oceanic and Atmospheric Administration's National Weather Service Atlas 14 which can be located at [https://hdsc.nws.noaa.gov/hdsc/pfds/pfds\\_map\\_cont.html](https://hdsc.nws.noaa.gov/hdsc/pfds/pfds_map_cont.html) ; or
  - (b) Once every 14 calendar days and within 24 hours of the occurrence of a storm event of 0.25 inches of precipitation or greater, or the occurrence of runoff from snowmelt. To determine if a storm event of 0.25 inches or greater has occurred on the site, the permittee shall either keep a properly maintained rain gauge on site, or obtain the storm event information from a weather station near the site location.
    - 1) Inspections are only required during the project's normal working hours.
    - 2) An inspection must be conducted within 24 hours of a storm event which has produced 0.25 inches. The inspection shall be conducted within 24 hours of the event end, or within 72 hours if the rain event ceases during a non-work day such as a weekend or holiday.

3) If it is elected to inspect every 14 calendar days and there is a storm event at the site that continues for multiple days, and each day of the storm produces 0.25 inches or more of rain, the permittee shall conduct an inspection within 24 hours of the end of the storm or within 72 hours if the rain event ceases during a non-work day such as a weekend or holiday.

The person responsible for erosion control is to be present on site every day during duration of the project to verify if stormwater runoff occurs, if they are not, they shall daily check the storm event information from a weather station near the site location.

- Parts that have been finally stabilized shall be inspected once per month. All perimeter controls shall be inspected weekly for proper anchorage, leakage, or tears on the control material;
- The responsible party shall make records of the installation and of all maintenance and repairs, and shall retain the records for at least five (5) years;
- Built-up sediment will be removed from silt barriers when it has reached 1/3 of the height of the barrier;
- Sediment basins shall have built-up sediment removed when 1/3 of the basin volume is filled;
- All measures shall be maintained in good working order;
- The project permit may be terminated when all projects are stabilized. This project is considered to be finally stabilized when perennial vegetation, pavement, buildings, or structures using permanent materials cover all areas that have been disturbed. With respect to areas that have been vegetated, vegetations cover shall be at least 70% over 100% of the site.

# GOOD HOUSEKEEPING

## **SPILL PREVENTION:**

### **PETROLEUM PRODUCTS**

- Construction equipment and vehicles shall be monitored for leaks and receive regular preventative maintenance to ensure proper operation and reduce the risk for leaks or spills.
- Petroleum products shall be stored in clearly labeled and tightly sealed containers or tanks.
- Any soil contaminated by fuel or oil spills shall be removed and disposed of properly.
- Above-or-below ground petroleum storage facilities must be set back 300 feet from any stream.
- Storage for oils, greases, paints, fuels, and chemicals shall be provided with secondary containment.

### **FUELING AND SERVICING**

- Above-or-below ground fueling storage facilities must be set back 300 feet from any stream.
- Up to 500 gallons of gasoline or diesel fuel is allowed, but must remain outside the stream buffer.
- Secondary containment for fuel shall be provided.

### **MUD TRACKING**

- The permittee is responsible for keeping sediment and debris off streets.

### **CONCRETE TRUCK WASHOUT**

- Washout shall not discharge surplus concrete or drum wash water on the site in such a manner that promotes contact with storm waters or natural streams discharging from the site.
- No concrete trucks will be on site and washout areas are not anticipated to be needed.
- A concrete washout area with proper controls will be made available by contractor if needed

### **HAZARDOUS MATERIALS**

- All hazardous materials shall be disposed of according to state regulation or the manufacturer's recommendations. MU-EHS will handle the disposal of all hazardous materials. Under no circumstances is this material to be removed from the site without EHS approval.

### **FERTILIZERS**

- Fertilizers shall be applied following manufacture's recommendations.
- Fertilizers shall be stored in a covered area or in watertight containers.
- Partially used products shall be properly sealed and stored to avoid spills or leaks.
- Up to 20 gallons of liquid fertilizer or pesticide and up to 100 pounds of granular fertilizer or pesticide storage is allowed if set back from stream 300 feet.
- Storage must remain out of the stream buffer.

### **CONSTRUCTION WASTE**

- All construction waste material shall be collected, deposited, and stored in a manner to prevent contact with storm waters discharging from the site and shall be disposed of by a licensed solid waste management contractor.
- No waste shall be buried on site.

### **SANITARY WASTE**

- A licensed sanitary waste management contractor shall collect all sanitary waste from portable units that will be maintained on a regular basis from any site that cannot provide other means of sanitary waste disposal.

# GOOD HOUSEKEEPING

## AIR EMISSIONS:

---

### BURNING

- Any burning on the site requires a permit from the Missouri Department of Natural Resources. Call EHS if any burning is to take place. EHS will obtain any necessary permits.

### DUST CONTROL

- The contractor is required by Missouri State law to control dust from the site.
- Watering must be provided in unstabilized areas and mulch applied as soon as possible.

## OTHER GOOD HOUSEKEEPING PRACTICES:

---

- Whenever possible, all of a product will be used up before disposing of the container in accordance with Missouri State law.
- Manufacturer's recommendations for proper use and disposal will be followed.
- The site manager shall inspect materials daily to ensure proper use, storage, and disposal.
- All paint containers will be tightly sealed and stored when not required for use. Excess paint will not be dumped into the stormwater system, but will be properly disposed of according to Missouri State law.

## SPILL CONTROLS:

---

- Manufacturer's recommended methods for spill cleanup will be clearly posted and site personnel will be made aware of the procedures and the location of the information and cleanup supplies.
- All spills will be cleaned up immediately after discovery.
- The spill area will be kept well ventilated and personnel will wear appropriate protective clothing to prevent injury from contact with a hazardous substance.
- If the permittee or an authorized representative has knowledge of any known or suspected release of materials which are resulting or may result in illegal discharges or pollutants discharging into stormwater, the storm drain system, or water of the U.S., said person shall take all necessary steps to ensure the discovery, containment, and cleanup of such release.
- The permittee or authorized representative is required to notify emergency response agencies of the occurrence via emergency dispatch services and the MDNR Environmental Emergency Response in accordance with 40 CFR 117 and CFR 302 as soon as they have knowledge of the discharge of any hazardous substance or petroleum product in excess of the reportable quantity.
- The applicant shall notify the Owners Representative of any oil spills or if hazardous substances are found during the prosecution of work under this permit. Any Notifications should be made to the Owners Representative, who will contact MU EHS. MU EHS shall determine if notification of DNR is required. If there is an immediate danger to life and health call 911
- The spill prevention plan will be adjusted to include measures to prevent this type of spill from reoccurring and how to clean up the spill if there is another one.

## SAMPLING REQUIREMENTS:

---

- There are no sampling requirements required as a part of this plan.

**LOG OF CHANGES TO THE SWPPP**

Document changes to the SWPPP here. These should include additions of new BMPs, replacement of failed BMPs, changes in construction activities and times, changes in personnel, inspection, and maintenance procedures, and updates to the site map.

UPDATE	DATE

# MU PROJECT CP241991

## SWPPP LOCATION MAP

SCALE: 1" = 60'

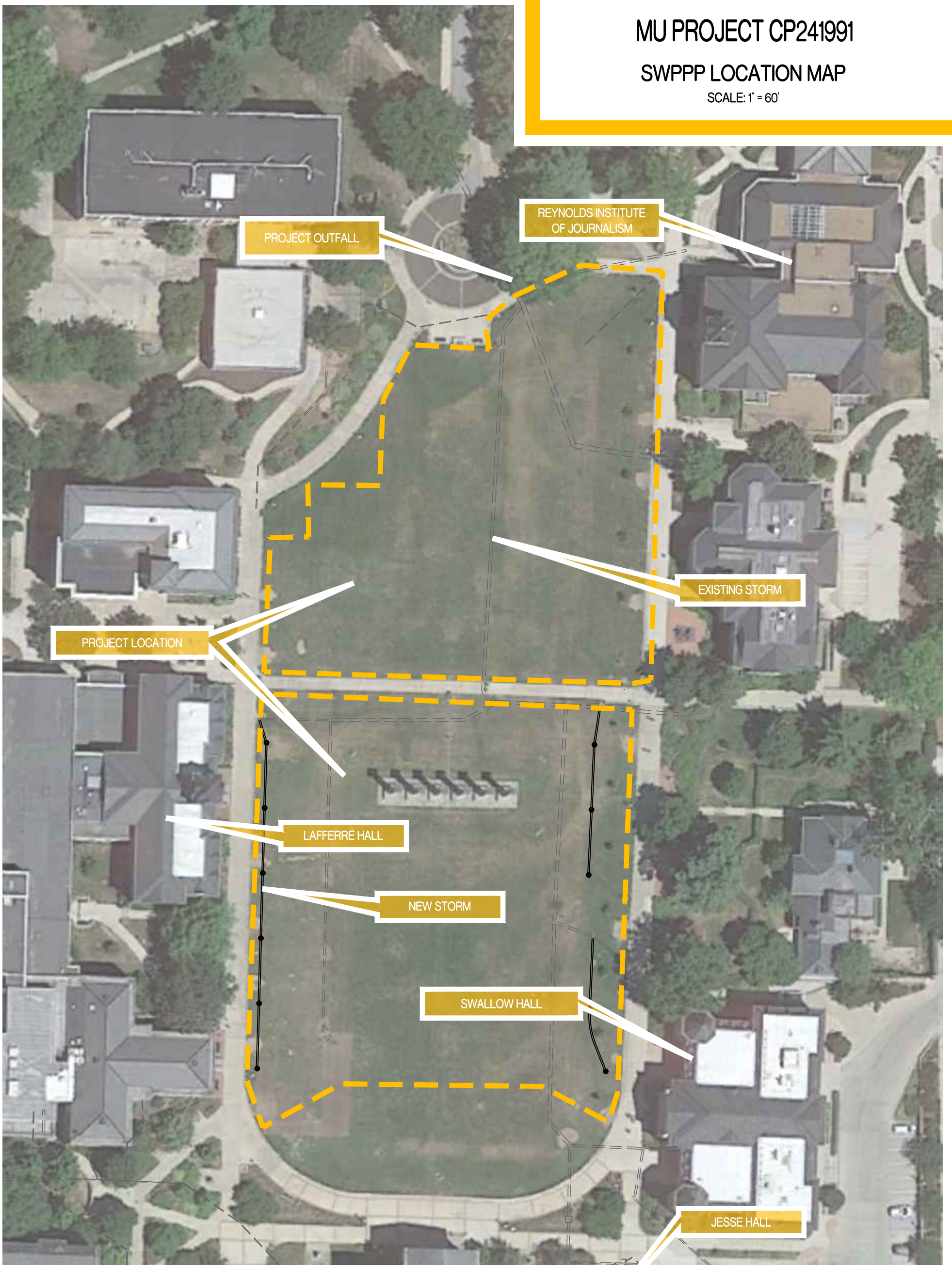

PREPARED BY:

**CROCKETT**  
ENGINEERING CONSULTANTS

1000 W. Nifong Blvd., Bldg. 1  
Columbia, Missouri 65203  
(573) 447-0292

[www.crockettengineering.com](http://www.crockettengineering.com)

Crockett Engineering Consultants, LLC  
Missouri Certificate of Authority  
#2000151301

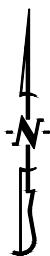

# MU PROJECT CP241991

## SWPPP LOCATION MAP

SCALE: 1" = 200'

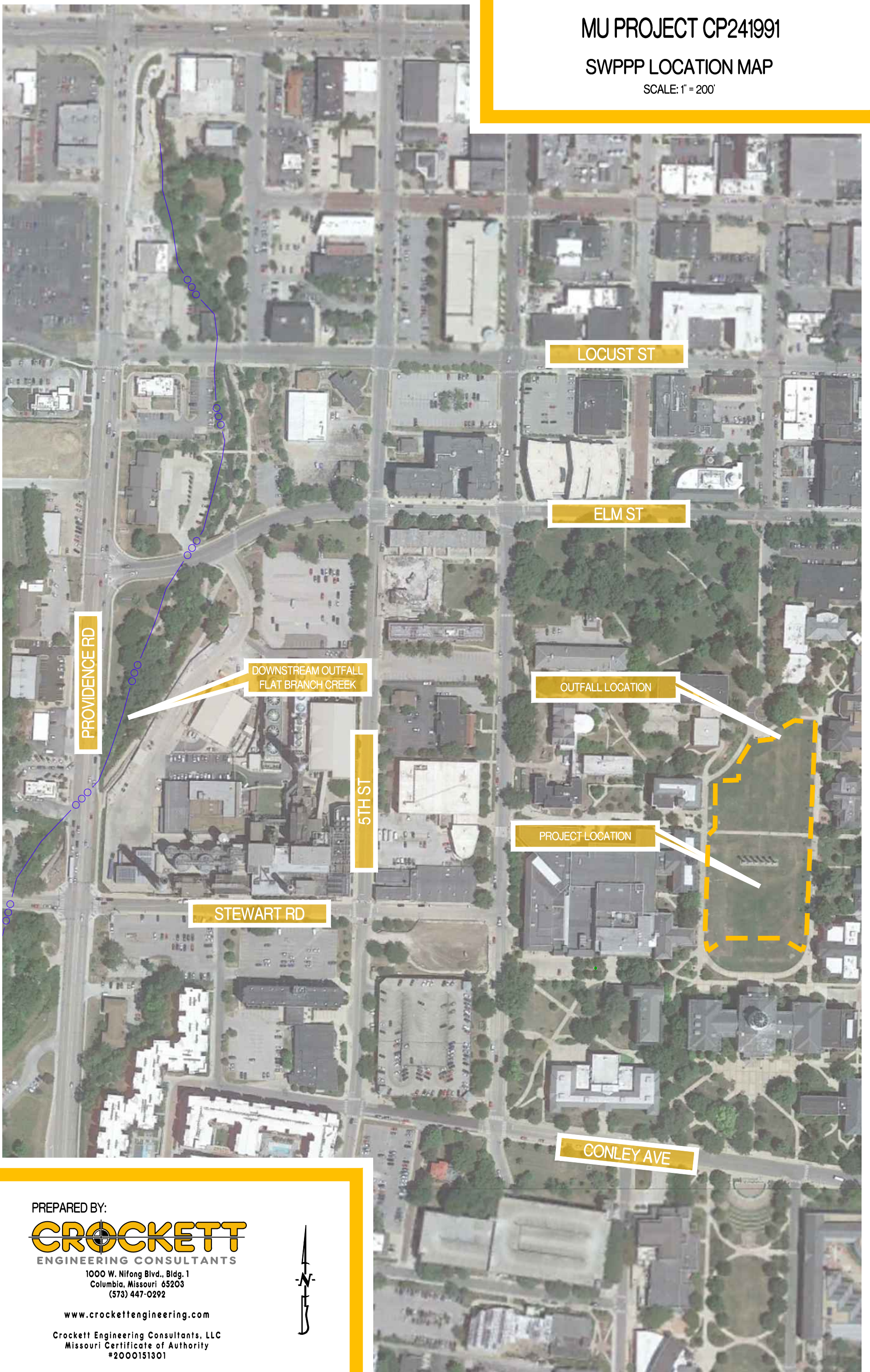

PREPARED BY:

**CROCKETT**  
ENGINEERING CONSULTANTS

1000 W. Nifong Blvd., Bldg. 1  
Columbia, Missouri 65203  
(573) 447-0292

[www.crockettengineering.com](http://www.crockettengineering.com)

Crockett Engineering Consultants, LLC  
Missouri Certificate of Authority  
#2000151301

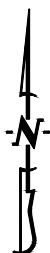



## SCHEDULING

### PHYSICAL DESCRIPTION

This BMP involves developing, a schedule that includes sequencing of construction activities with the implementation of construction site BMPs such as temporary soil stabilization (erosion control) and temporary sediment control measures for every project. The purpose is to reduce the amount and duration of soil exposed to erosion by wind, rain, runoff and vehicle tracking, and to perform the construction activities and control practices in accordance with the planned schedule.

### APPROPRIATE APPLICATIONS:

Construction sequencing shall be scheduled to minimize land disturbance for all projects at all times.

### CONDITIONS FOR EFFECTIVE USE:

All land disturbing activities.

### WHEN BMP IS TO BE INSTALLED:

Scheduling should take place during the planning stages and be modified throughout the duration of the project.

### STANDARDS AND SPECIFICATIONS:

Developing a schedule and planning the project are the very first steps in an effective storm water program. The construction schedule shall be incorporated into the SWPPP. Develop the sequencing and timetable for the start and completion of each item such as site clearing and grubbing, grading, excavation, paving, pouring foundations, installing utilities, etc., to minimize the active construction area during the rainy season. Schedule major grading operations for the non-rainy season when practical. Incorporate staged seeding and re-vegetation of graded slopes as work progresses. Consider the appropriate planting time for specified vegetation when establishing permanent vegetation.

### OPERATION AND MAINTENANCE PROCEDURES:

Verify that work is progressing in accordance with the schedule. If progress deviates, take corrective actions. Amend the schedule when changes are warranted.

## CONSTRUCTION ENTRANCE/EXIT

### PHYSICAL DESCRIPTION

A stabilized entrance to a construction site which is designed to minimize the amount of sediment tracked from the site on vehicles and equipment. Mud and sediment fall off of tires as they travel along the stabilized entrance.

### APPROPRIATE APPLICATIONS:

At locations where it is safe for construction vehicles and equipment to access existing streets, preferably at the location of future streets or drives.

### CONDITIONS FOR EFFECTIVE USE:

Site conditions will dictate design and need. Ditches or pipes, if needed, sized for 15 year, 20 minute storm; HGL 6" below surface of entrance.

### WHEN BMP IS TO BE INSTALLED:

Install stabilized construction entrance/exit prior to vehicles or equipment accessing unpaved areas. This will most likely be the first BMP to be installed on the site.

### STANDARDS AND SPECIFICATIONS:

Limit the points of entrance/exit to the construction site. Properly grade and compact each construction entrance/exit to prevent runoff from leaving the site. Install culvert under entrance if needed to maintain positive drainage. Place fabric and cover with aggregate, forming a diversion across the entrance, if needed, to direct runoff away from the roadway. Require all employees, subcontractors, and suppliers to utilize the stabilized construction access.

### OPERATION AND MAINTENANCE PROCEDURES:

Inspect routinely for damage and assess effectiveness of the BMP. Remove sediment and clods of dirt from construction entrance continuously. Replace rock, as necessary, to maintain a clean surface for traffic. Repair any areas that have settled. Keep all temporary roadway ditches clear. Immediately remove any mud or debris tracked onto paved surfaces.

### SITE CONDITIONS FOR REMOVAL:

Remove when vehicles and equipment will no longer require access to unpaved areas.

## CONSTRUCTION ENTRANCE/EXIT

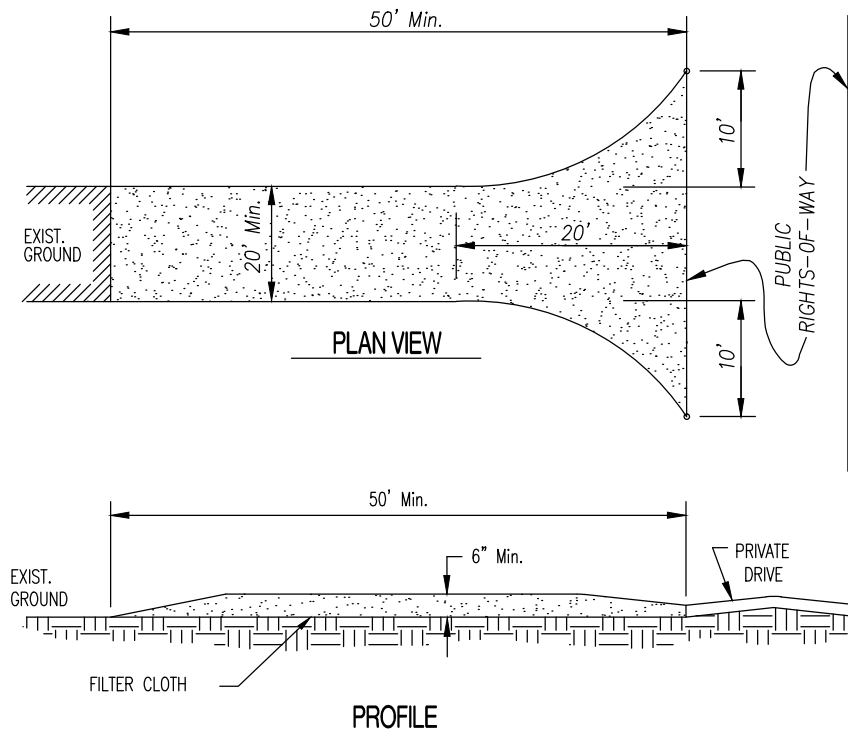

### CONSTRUCTION SPECIFICATIONS

1. STONE SIZE - USE 2' STONE.
2. LENGTH - AS REQUIRED, BUT NOT LESS THAN 50 FEET.
3. THICKNESS - NOT LESS THAN SIX (6) INCHES.
4. WIDTH - TWENTY (20) FOOT MINIMUM, BUT NOT LESS THAN THE FULL WIDTH AT POINTS WHERE INGRESS OR EGRESS OCCURS.
5. FILTER CLOTH - WILL BE PLACED OVER THE ENTIRE AREA PRIOR TO PLACING OF STONE.
6. SURFACE WATER - ALL SURFACE WATER FLOWING OR DIVERTED TOWARD CONSTRUCTION ENTRANCES SHALL BE PIPED ACROSS THE ENTRANCE. IF PIPING IS IMPRACTICAL, A MOUNTABLE BERM WITH 3:1 SLOPES WILL BE PERMITTED.
7. MAINTENANCE - THE ENTRANCE SHALL BE MAINTAINED IN A CONDITION WHICH WILL PREVENT TRACKING OR FLOWING OF SEDIMENT ONTO PUBLIC RIGHTS-OF-WAY. THIS MAY REQUIRE PERIODIC TOP DRESSING WITH ADDITIONAL STONE AS CONDITIONS DEMAND AND REPAIR AND/OR CLEANOUT OF ANY MEASURES USED TO TRAP SEDIMENT. ALL SEDIMENT SPILLED, DROPPED, WASHED OR TRACKED ONTO PUBLIC RIGHTS-OF-WAY MUST BE REMOVED IMMEDIATELY.
8. PERIODIC INSPECTION AS NEEDED MAINTENANCE SHALL BE PROVIDED WEEKLY AND AFTER EACH RAIN EVENT GREATER THAN 1/2".

## DROP INLET PROTECTION

### PHYSICAL DESCRIPTION

A temporary sediment control barrier consisting of a filter fabric around a recessed area inlet designed to prevent sediment from entering the storm sewer. Shallow temporary ponding may occur during and after rainfall events.

### APPROPRIATE APPLICATIONS:

At recessed area or yard inlets where runoff may contain sediment-laden water.

### CONDITIONS FOR EFFECTIVE USE:

Type of Flow: Sheet flow and concentrated flow.

Contributing Area: Maximum of 1 acre.

### WHEN BMP IS TO BE INSTALLED:

Place inlet protection immediately after installation of the inlet, or prior to land disturbing activities beginning on the contributing upstream area to the inlet.

### STANDARDS AND SPECIFICATIONS:

Typical types of drop inlet protection include: manufactured filtering product or silt fence frames. Follow the manufacturer's instruction for placement of proprietary products. For the silt fence protection, install a wood frame, dig a trench around the inlet for fabric to be buried, fasten fabric tightly to frame, backfill and compact trench. Alternatively, a sod filter can be installed by preparing and fertilizing the soil around the inlet and installing sod for a distance of at least 4 feet in each direction. The sod should be staked, stapled and/or netted at the corners and center of sod strips as required and then watered immediately. For safety, inlet protection structures which pond water onto streets, parking lots or driveways should be designed to have some method for allowing excess water from large storms to bypass or overflow.

### OPERATION AND MAINTENANCE PROCEDURES:

Inspect inlet protection of all media types weekly and after each significant rainfall event to make sure they are functioning properly. Remove trash and debris. Remove sediment from the inlet protection when half of the protection structure height has been filled. Repair elements to original configuration as needed.

### SITE CONDITIONS FOR REMOVAL:

Remove after contributing drainage areas have been adequately stabilized.

# DROP INLET PROTECTION

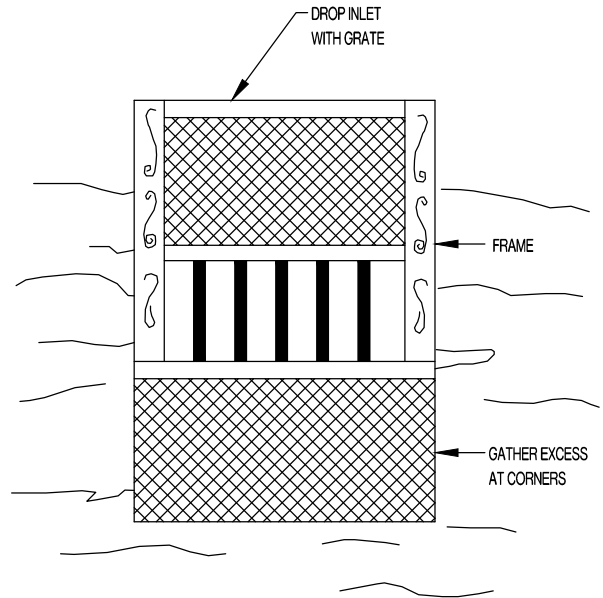
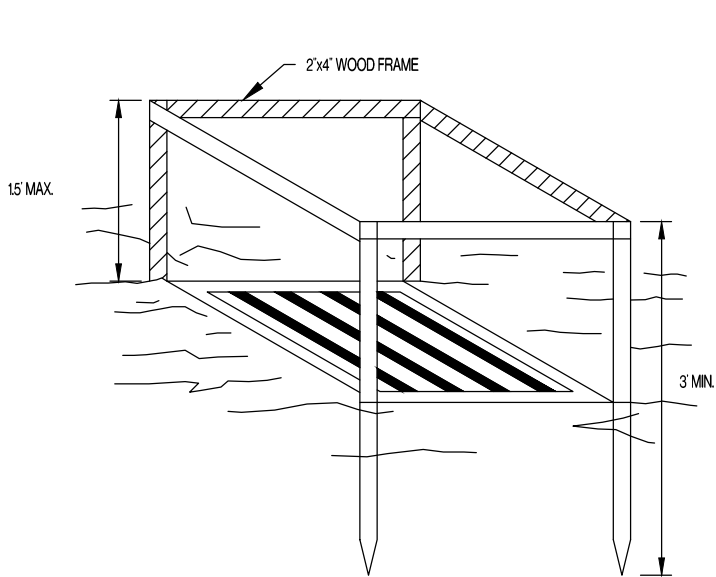

PERSPECTIVE VIEWS  
NOT TO SCALE

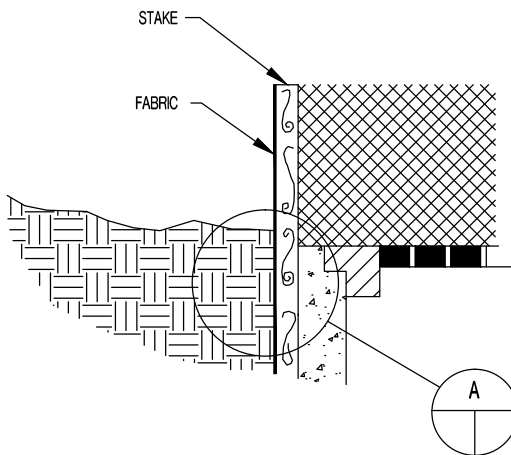

ELEVATION OF STAKE AND  
FABRIC ORIENTATION

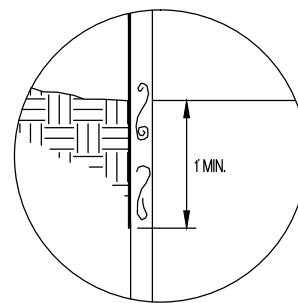

DETAIL A  
NOT TO SCALE

## DUST (WIND EROSION) CONTROL

### PHYSICAL DESCRIPTION

Wind erosion control consists of applying water and/or other dust palliatives as necessary to prevent or alleviate erosion by the forces of wind. Alternatives to applying water or other dust palliatives include mulch or vegetative cover, wind barriers, and minimization of soil disturbance.

### APPROPRIATE APPLICATIONS:

This practice is implemented on all exposed soils subject to wind erosion.

### CONDITIONS FOR EFFECTIVE USE:

Effectiveness depends on soil, temperature, slope, aspect, humidity and wind velocity.

### WHEN BMP IS TO BE INSTALLED:

Dust control should be performed routinely, especially in advance of and during periods of dry weather.

### STANDARDS AND SPECIFICATIONS:

Water shall be applied by means of pressure-type distributors or pipelines equipped with a spray system or hoses and nozzles that will ensure even distribution. Phase work to the extent practical to minimize concurrent areas of soil disturbance. For areas not subjected to traffic, vegetation provides the most practical method of dust control and should be established as early as possible. Wind barriers such as solid board fences, snow fences, burlap fences, crate walls, and similar materials can be used to control air currents and blowing soil. Barriers placed at right angles to prevailing wind currents at intervals of about 10 times their height are effective in controlling soil blowing. Paved areas that have soil on them from construction sites should be cleaned regularly. Mulching offers a fast and effective means of controlling dust when properly applied. Binders and tackifiers may need to be used on organic mulches. NOTE: If calcium chloride or spray-on adhesives are used for dust control, a permit may be required from MoDNR.

### OPERATION AND MAINTENANCE PROCEDURES:

Check areas that have been protected to ensure coverage.

### SITE CONDITIONS FOR REMOVAL:

Dust control should be implemented when soils are exposed until cover is established

## NON-SEDIMENT POLLUTION CONTROL

### PHYSICAL DESCRIPTION

These control measures are designed to prohibit chemicals, hazardous materials, solid waste, human waste and construction debris from polluting stormwater. Pollutants carried in solution or as surface films on runoff will be carried through most erosion control and sediment capture BMPs. Keeping substances like fuel, oil, asphalt, paint, solvents, fertilizer, soil additives, concrete wash water, solid waste, human waste and construction debris from polluting runoff can be accomplished to a large extent through good housekeeping on the site and following the manufacturer's recommendations for disposal.

### APPROPRIATE APPLICATIONS:

Temporary sanitary facilities, collection, storage and fueling areas should be located onsite in an area that does not receive a substantial amount of runoff from upland areas and does not drain directly to lakes, creeks, streams, rivers, sewers, groundwater, wetlands, or road ditches.

### CONDITIONS FOR EFFECTIVE USE:

An effective management system requires training and signage to promote proper storage, handling and disposal of materials, and follow up observations of actions and inspection of storage areas by management. Plans should contain notes clearly stating requirements for addressing potential pollutants.

### WHEN BMP IS TO BE INSTALLED:

Pollution control practices should begin immediately and continue throughout the project.

### STANDARDS AND SPECIFICATIONS:

Place waste receptacles near area of work. All fueling facilities present on the site shall adhere to applicable federal and state regulations concerning underground storage, above ground storage, and dispensers. Hazardous wastes shall be managed according to Missouri Hazardous Waste Laws and Regulations. Install appropriate signage. Post guidelines for proper handling, storage and disposal of materials, and emergency spill cleanup on site. Provide sufficient temporary toilet facilities to serve the number of workers on the site.

### OPERATION AND MAINTENANCE PROCEDURES:

Inspect activities on a regular basis. Inspect storage areas and control devices at least every week and after every storm. Maintenance of temporary toilet facilities should be frequent and thorough. Make necessary corrections and repairs.

### SITE CONDITIONS FOR REMOVAL:

Remove after contributing drainage areas have been adequately stabilized.

## STANDARD NOTES:

### General pollution notes:

#### 1. Handling and disposal of hazardous materials:

DO: Prevent spills

Use up products completely

Follow label directions for disposal

Remove lids from empty bottles and cans when disposing in trash

Recycle wastes whenever possible

DON'T: Don't pour waste into sewers or waterways on the ground

Don't pour waste down the sink, floor drain or septic tanks

Don't bury chemicals or containers, or dispose of them with other waste

Don't burn chemicals or containers

Don't mix chemicals together

2. Containers shall be provided for collection of all waste material including construction debris, trash, petroleum products and any hazardous materials to be used onsite. All waste material shall be disposed of at facilities approved for that material under the guidance of MU-EHS only.

3. No waste materials shall be buried on-site.

4. Mixing, pumping, transferring or otherwise handling construction chemicals such as fertilizer, lime, asphalt, concrete drying compounds, and all other potentially hazardous materials shall be performed in an area away from any watercourse, ditch or storm drain.

5. Equipment fueling and maintenance, oil changing, etc., shall be performed only in an area designated for that purpose. The designated area is equipped for recycling oil and catching spills.

6. Concrete wash water shall not be allowed to flow directly to storm sewers, streams, ditches, lakes, etc without being treated. A sump or pit shall be constructed to contain concrete wash water.



7. All paint, solvents, petroleum products and petroleum waste products, and storage containers (such as drums, cans, or cartons) shall be stored according to BMPs. The materials exposed to precipitation shall be stored in watertight, structurally sound, closed containers. All containers shall be inspected for leaks or spillage during the once per week inspection of BMPs. If substances such as oil, diesel fuel, hydraulic fluid, antifreeze, etc. are spilled, leaked, or released onto soil, the soil shall be dug up by or under the guidance of MU-EHS and properly disposed of. Spills on pavement shall be absorbed with sawdust, kitty litter or product designed for that purpose and disposed of at a licensed sanitary landfill. Hazardous or industrial wastes such as most solvents, gasoline, oil-based paints, and cement curing compounds require special handling. These materials will be removed from the site and recycled or disposed of in accordance with MoDNR requirements.

8. State law requires the party responsible for a petroleum product spill in excess of 50 gallons to report the spill to MoDNR (537-634-2436) as soon as practical after discovery. Federal law requires the responsible party to report any release of oil if it reaches or threatens a sewer, lake, creek, stream, river, groundwater, wetland, or area, like a road ditch, that drains into one of the above.

9. Sufficient temporary toilet facilities to serve the number of workers on the site shall be provided. The facilities shall be serviced frequently to maintain a sanitary condition.

# SPILL OR INCIDENT REPORT FORM

Complete this form for any type of petroleum product or hazardous materials/waste spill or incident.  
MU-EHS must be notified of all spills at the time of incident  
(Keep a copy of this report with the SWPPP Log.)

## GENERAL INFORMATION

Site: \_\_\_\_\_

Date: \_\_\_\_\_ Date of Incident: \_\_\_\_\_

Primary Contractor: \_\_\_\_\_

## PERSON REPORTING SPILL OR INCIDENT

Name: \_\_\_\_\_

Organization: \_\_\_\_\_ Title: \_\_\_\_\_

Address: \_\_\_\_\_

Telephone: \_\_\_\_\_ Fax: \_\_\_\_\_

Signature: \_\_\_\_\_

## TYPE OF SPILL

Common Name of Spilled Substance: \_\_\_\_\_

Estimated Quantity Spilled: \_\_\_\_\_ Estimated Concentration: \_\_\_\_\_

Date of Spill: \_\_\_\_\_

Time Spill Started: \_\_\_\_\_ (AM/PM) Time Spill Ended: \_\_\_\_\_ (AM/PM)

## SPILL TO LAND

Name of Site: \_\_\_\_\_

Address: \_\_\_\_\_

City: \_\_\_\_\_ County: \_\_\_\_\_

## SPILL TO WATER BODY

Name of Water Body: \_\_\_\_\_

Location of Discharge: \_\_\_\_\_

Description of Area from Which Spilled Material May Reach: \_\_\_\_\_

\_\_\_\_\_

**INCIDENT**

If No Spill, Describe Incident: \_\_\_\_\_  
\_\_\_\_\_  
\_\_\_\_\_

**ACTIONS TAKEN**

To Contain Spill or Impact of Incident: \_\_\_\_\_  
\_\_\_\_\_

To Clean Up Spill or Recover from Incident: \_\_\_\_\_  
\_\_\_\_\_

To Remove Cleanup Material: \_\_\_\_\_  
\_\_\_\_\_

To Prevent Reoccurrence: \_\_\_\_\_  
\_\_\_\_\_

**PERSON RESPONSIBLE FOR MANAGING SPILL REPOSE**

Name: \_\_\_\_\_ Signature: \_\_\_\_\_

Telephone: \_\_\_\_\_ Fax: \_\_\_\_\_

## SPILL REPORTING INFORMATION

Where is the Spill: \_\_\_\_\_

What Spilled: \_\_\_\_\_

How Much Spilled: \_\_\_\_\_

How Concentrated is the Spilled Material: \_\_\_\_\_

Who Spilled the Material: \_\_\_\_\_

Is Anyone Cleaning up the Spill: \_\_\_\_\_

Are There Resource Damages (e.g. dead fish or oiled birds): \_\_\_\_\_

\_\_\_\_\_

Who is Reporting the Spill: \_\_\_\_\_

Has MU-EHS been notified as required? \_\_\_\_\_

Your Name: \_\_\_\_\_ Your Telephone: \_\_\_\_\_